

www.rosler.com

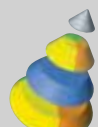

*Continuous flow shotblasting systems
Types RDGE, RMBD and SBM*

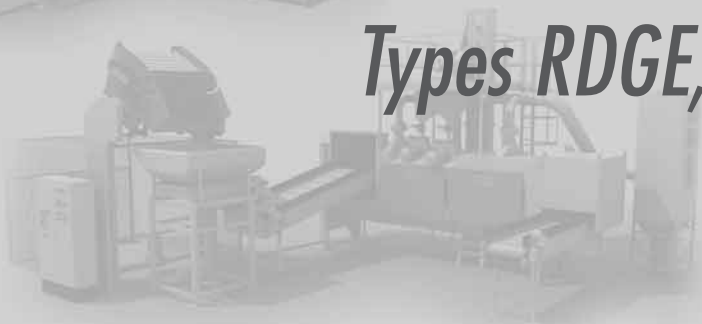

Continuous flow shotblasting systems

Types RDGE, RMBD and SBM

Rösler continuous flow shotblasting machines are excellent for all-around complete and continuous blasting of flat, voluminous, or complex components. Our powerful Hurricane® blast wheels are mounted to the blast cabin housing in the most optimum positions to further insure uniform blast coverage of the components.

Each machine type has a unique component transport system and our process engineers are ready to help you choose a machine type that will satisfy your blasting needs.

▶ Hurricane® Blast Wheels

These high performance blast wheels are specially designed for optimum performance and are at the heart of the Rösler shotblasting program. Each blast wheel is clearly identified by a number and the wheels are specially placed on the cabin housing to produce the most effective and productive blast pattern possible.

▶ Filter Systems

Dry or wet, with or without explosion protection, Rösler provides a wide range of filters constructed with cutting edge technology. The design and construction of our filters take into account the latest rules and regulations regarding dust removal in blasting applications.

▶ Automation

Rösler continuous flow shotblasting machines can be easily combined with automatic loading and unloading systems, allowing simple integration into automatic production lines at any time.



Quality – made in Germany..

For Rösler the word quality has deeper meaning than just faultless, reliable and long living products. Quality is an essential part of our work philosophy and is expressed in the personal sense of duty and quality found in each of our employees. Certification according to DIN ISO 9001 is livingproof of our commitment to quality.



Application possibilities

Cleaning

Pumps and fittings · forged parts · plasma cut parts ...

Decorating

Fittings · steel and sand castings · engine components ...

Blast cleaning

Precision (investment) and nonferrous castings · forgings · chill castings ...

Decorative blasting

Light alloy · stainless steel · nonferrous metal surfaces ...

Shot Peening

Springs · rings · sprockets · pinions · connecting rods ...

Deburring

Die castings · small parts · stamped parts · laser cut parts ...



Rösler-Hurricane® Blast Wheels

Blasting media is fed centrally to a high speed rotating blast wheel. The centrifugal force, of the rotating wheel, throws the media at the components to be blasted at speeds up to 120 m/s. The design of the blades, insertion point, and the speed of the blast wheel determine the processing results in conjunction with the blasting media.

In order to achieve an economic utilization of the blasting media, the amount of blasting media and the transfer to the blast wheel blades can be easily adjusted. The blasting media feed control can be optionally fully automatic. After the end of the shotblasting cycle, a shell valve closes the blasting media feed. Blasting media distribution and the setting of the blasting stream (hotspot) are accomplished externally in a user-friendly manner at the blasting media feed tube. If desired, the blast speed can be regulated by adjusting the rotation speed, allowing various surface grades and processing alternatives.

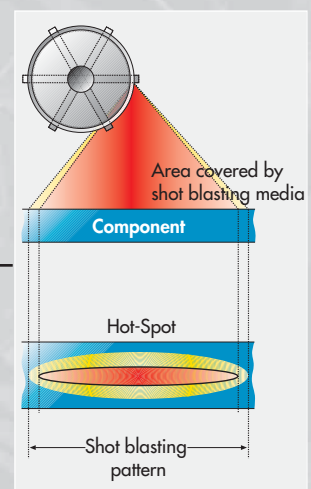
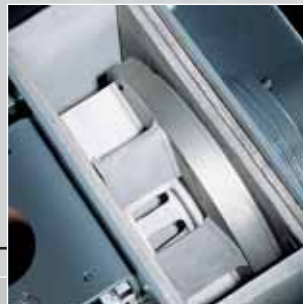

Blasting profile

Blast wheels

Type/wheel diameter	Drive power (kW)
Hurricane® 28	5,5
	7,5
	11,0
Hurricane® 32	5,5
	7,5
	11,0
Hurricane® 42	11,0
	15,0
	18,5
	22,0
Hurricane® 52	22,0
	30,0
	37,0
	45,0

Tool steel, alternative: carbide

effective: 01/07

Blast Wheel Hurricane[®]

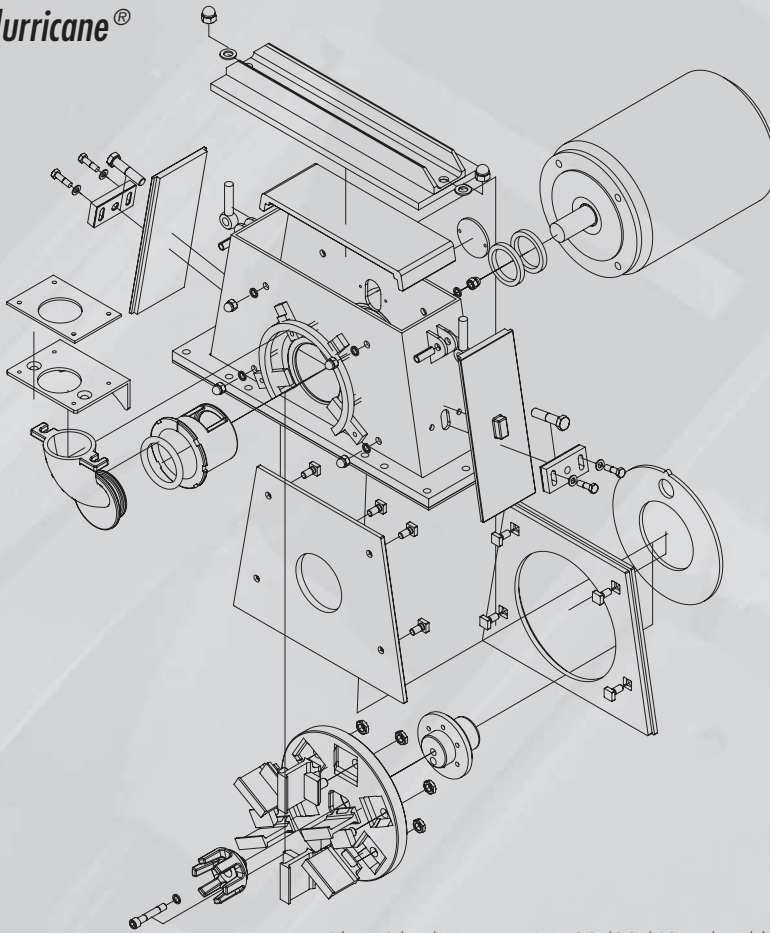

*Blast Wheel Hurricane[®] H 28/32/42 with 6 blades
Blast Wheel Hurricane[®] H 52 with 8 blades*

Technical features of the blast wheels

- ▶ Short processing times
- ▶ Long useful blast wheel life
- ▶ High shotblasting performance
- ▶ No internal fixturing of blades
- ▶ Easy accessibility and easy replacement of the blades
- ▶ Direct drive, fewer wear parts, such as the bearing block, lower noise levels
- ▶ Blades, impeller unit, control cage, manufactured in full tungsten carbide
- ▶ Blast wheel can be used clockwise or counter-clockwise
- ▶ Blast wheel diameter available up to 520 mm
- ▶ Lid with final limit switch
- ▶ Massive welded steel housing
- ▶ Short spare part delivery times
- ▶ Exchangeable wear-and-tear plates (chilled cast iron and/or doubled manganese steel) in the housing

Rösler RDGE wire mesh belt machine

For all-around complete and continuous blasting of medium to large components.

Machine layout

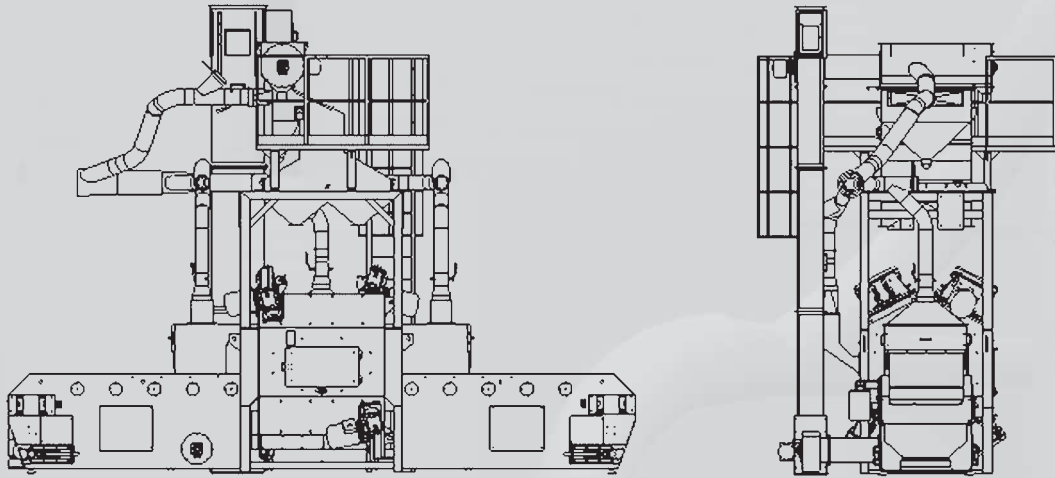

Technical data:	RDGE 800-2 (4,8)	RDGE 1000-4 (8)	RDGE 1250-4 (8)
Blast wheel types	Hurricane® 28, 32, 42		
Number of blast wheels	Available in groups of 2, 4 or 8		
Blast wheel motor power	5,5 – 15 kW		
Max. belt weight	100 kg/meter		
Max. belt width	800 mm	1000 mm	1250 mm
Max. throughput height	400 mm	400 mm	500 mm
Loading height	1000 mm		
Machine length	7000 mm		
Total machine height	approx. 5300 mm		
Media cleaning methods	rotating drum screen, airwash separator, and dust collecting system		
Required min. airflow for dust collection system	4.000 – 10.000 m ³ /h		

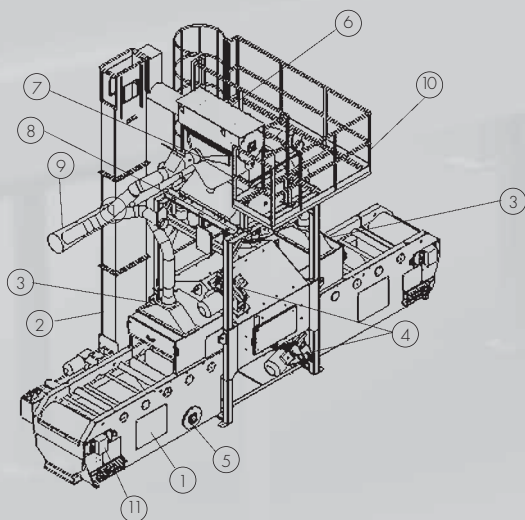

- | | | | |
|---|-----------------------------|----|-----------------------------|
| 1 | Machine housing | 7 | Airwash separator |
| 2 | Bucket elevator | 8 | Blasting media hopper |
| 3 | Dust extraction connections | 9 | Dust collector tubing |
| 4 | Blast wheels | 10 | Inspection platform |
| 5 | Belt guiding roll | 11 | Wire mesh belt speed sensor |
| 6 | Rotating drum screen | | |



Technical features:

- ▶ Continuous flow blasting process
- ▶ Design allows for the integration of robot units for fully automatic loading and unloading
- ▶ Available with two, four or eight blast wheels for optimal blasting results
- ▶ Uniform processing of complex component contours
- ▶ High process reliability with all-around blasting result
- ▶ Parallel part transport through the machine can be enabled thanks to the division of the wire mesh belt into rows (double-track transport)
- ▶ Processing of long components (profiles, beams) is possible, as well as the secure blasting of small components and parts, which can not be transported through roller conveyor machines
- ▶ The wire mesh belt is available in either spring or manganese steel
- ▶ Easily integrated into existing production lines
- ▶ Used blast media is cleaned via an airwash separator that can be equipped with an optional magnetic separator
- ▶ Discharge of large particles from the used blast media can be achieved by a rotating drum screen

The RDGE in detail

Technically advanced process solutions, combined with proven machine components, ensure the Rösler wire mesh belt machines system functions reliably under tough conditions.

Wire mesh belt continuous flow shot-blasting machine

- ▶ Stable, torsion resistant construction **1**
- ▶ Equipped with large maintenance openings for easy access to internal components **2**
- ▶ No special foundation or pit required
- ▶ Integration into automatic systems is possible
- ▶ Ergonomic component feeding height **3**

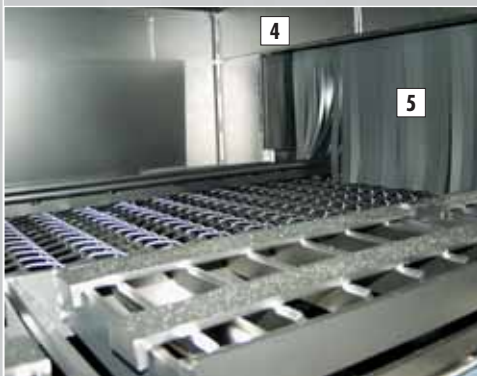

Blasting chamber

- ▶ Lined with manganese steel **4**
- ▶ Gapless protective plates screwed together from the outside
- ▶ Media recovery screw is covered in order to prevent premature wear
- ▶ Several suspended rubber curtains help to prevent the exit of blasting media **5**
- ▶ Dust collection connections are located in the entry chamber, blasting chamber, and exit chamber
- ▶ Manually operable service doors are protected by safety switches to prevent accidental opening during machine operation

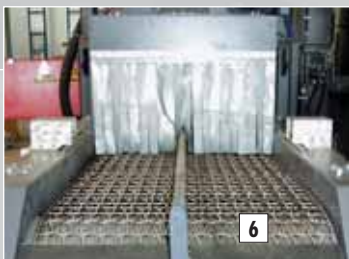

Component transport

- ▶ By special endless wire **6** mesh belt
Available in either spring or manganese steel
- ▶ External belt drive with torque and running control **7**
- ▶ Maintenance free, self lubricating bearings

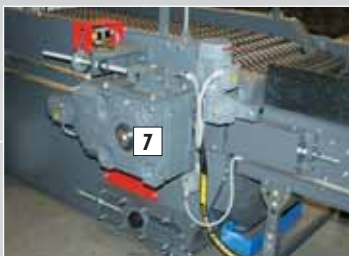

Blasting media cycle

Shotblasting system

- ▶ Hurricane[®] blast wheel **1**
- ▶ Easily exchangeable blades **2**
- ▶ Arranged in an ideal position in the blasting chamber
- ▶ Inspection cover protected by a control switch on the blast wheel housing **3**
- ▶ Completely lined housing with chilled cast iron protecting plates **4**

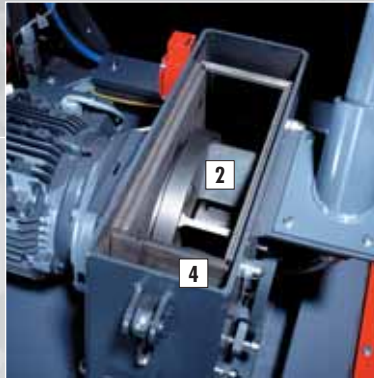

Automatic blasting media replenisher*

- ▶ Ensures constant blasting media operating mixture
- ▶ Includes minimum level control **5**
- ▶ Level activated pneumatic valve that feeds media directly to the bucket elevator **6**

* optional



Blasting media transport and cleaning

- ▶ Funnel-shaped manganese steel blast media hopper
- ▶ Screw conveyor for longitudinal and diagonal delivery of blasting media **7**
- ▶ Firmly sealed, automatic operating shell valve
- ▶ Short distance from the blast wheel
- ▶ Simple setting and adjustment action for the blasting media flow rate



Bucket elevator

- ▶ Compact, high wear-resistant, bolted buckets **8**
(= efficient blasting media separation due to controlled feed rate evenly distributed from each bucket)
- ▶ Special endless belt fitted with no-wear connectors
- ▶ Belt monitoring on the lower pulley
- ▶ Spherical running surfaces on the pulleys (centering of the belt)



Airflow separator

- ▶ Large separator width with blasting media flow regulation flap **1**
- ▶ Long sieving and cascade area (better blast media cleaning) **2**
- ▶ Separate air regulation valve **3**
- ▶ Easy to clean safety screen insert **4**
- ▶ Large blasting media hopper with minimum level sensor **5**
- ▶ Rotating screen, integrated into the air flow separator **6**

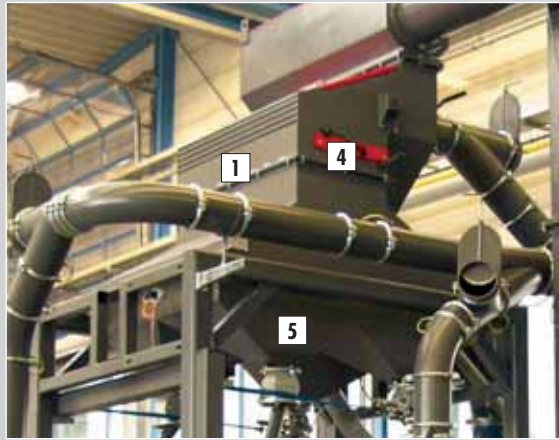

Central electric cabinet

- ▶ For controlling the individual system modules and functions



Automation

RDGE 800-4 for deburring and cleaning of aluminum die castings by means of **two transport lines** and corresponding **loading belts**. Excess blast media that has been carried out of the machine on the parts is removed in a special separating section and the re-transport of components is achieved via a set of conveyor belts



RDGE 800-4-KU for gentle deburring of aluminum profiles using plastic blasting media. Equipped with special blast wheels, an antistatic unit, and media replenishing unit.

RDGE 800-4 (8) for removal of sand from cast parts and return transport of components by means of vibratory conveyor. Subsequent discharge of excess blasting media is achieved in a special separation section. Prepared for equipment with eight blast wheel units.



Rösler RMBD tumble belt feed through shotblasting machine

For all-around complete and continuous blasting of parts which can be tumbled

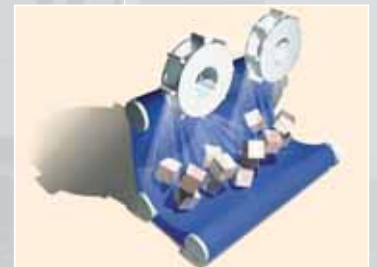

Technical features:

- ▶ Continuous tumbling of components with simultaneous feeding
- ▶ Smooth and gentle conveyance of components by special tumble belt rods
- ▶ A wide spectrum of components can be treated
- ▶ High degree of efficiency thanks to the short distance between the blast wheel and components
- ▶ A throughput of up to 10 tons of steel parts per hour is possible
- ▶ The removable transport system and individually exchangeable tumble belt rods allow for short maintenance times.
- ▶ Connection with automatic loading and unloading systems, and integration into existing production lines is possible at any time

Technical data:	RMBD 300/2	RMBD 400/2	RMBD 500/2 (4)
Part envelope	250 mm	350 mm	400 mm
Diameter of tumble belt	300 mm	400 mm	500 mm
Blast wheel types	Hurricane® 28, 32 and 42		
Number of blast wheels	2	2	2 or 4
Integrated separation	x	x	x
Machine length	4000 mm	5110 mm	5340 mm
Machine height	4100 mm	4300 mm	5200 mm
Blast wheel power	5,5 – 11 kW		

Rösler SBM continuous conveyor through feed machine

For all-around blasting of parts which can be tumbled inside of closed loop belts.



Technical features:

- ▶ Treatment of a wide variety of parts is possible thanks to the use of PU and manganese steel loop belts
- ▶ Highly efficient blast wheel system with simple design
- ▶ High throughput quantities resulting in extreme efficiency
- ▶ Integrated separation with automatic return of blasting media
- ▶ Processing of individual batches thanks to guided transport of components
- ▶ Connection with automatic loading and unloading systems, and integration into existing production lines is possible at any time

Technical data:	SBM 1010	SBM 1210	SBM 1520	SBM 2020
Max. part envelope	100 mm	190 mm	190 mm	265 mm
Max. length of component	210 mm	290 mm	290 mm	360 mm
Blast wheel types	Hurricane 28 and 32			
Number of blast wheels	1	1	2	2
Driving power	5,5 kW	7,5 kW	per 7,5 kW	per 11 kW
Throughput quantity¹	650 kg/h	1000 kg/h	2000 kg/h	2500 kg/h
Integrated separation	–	x	x	x
Machine length	2720 mm	3570 mm	4980 mm	5920 mm
Machine height	4040 mm	3600 mm	4420 mm	5430 mm

¹ in reference to steel parts

Test Centres and Service

Finding a better way... a commitment to our customers

Test Centres worldwide

Throughout our worldwide organization we adhere to strict quality control procedures. This applies especially to our test centres where we develop process solutions for all kinds of surface finishing problems. Each branch of the Rösler group features its own test centre equipped with the latest Rösler finishing equipment. This equipment is utilized exclusively for processing trials with our customer's sample parts.



For Rösler service is not just an empty promise

Professional advice, short turn-around times and prompt and reliable service: Rösler offers single-source surface finishing solutions, worldwide!

▶ Installation and training

Machine installations and operator training are performed by our team of highly skilled and experienced service engineers

▶ Spare parts service for all recognised shot blast systems

Surface finishing equipment generally is subject to a considerable amount of wear. For this reason preventive maintenance and prompt supply of spare parts are a key requirement for any surface finishing installation. Rösler maintains a complete inventory of spare parts in every branch, ensuring local supply and fast availability, be it wire mesh belts, blasting wheels, pressure vessels or any kind of nozzles, etc. To minimize downtime, parts are either delivered and installed by our own field service personnel or shipped to our customer's location overnight.

▶ Maintenance and repair service

Rösler maintains a well trained staff of professional field service engineers providing prompt, reliable maintenance and repair service at competitive rates as well as overhaul of your older equipment.

▶ Professional advice

Our finishing specialists stand ready to provide information regarding any kind of question relating to specific surface finishing problems. With decades of experience we will be able to provide you with the right answers.





Towards perfect interaction

The name ROSLER stands for technological leadership in the world of mechanical surface treatment. We offer our customers innovative products and services, a complete range of process engineering know-how, and the skills to link systems into perfect combinations. Right from the start, our strength has been user-related solutions, solutions which ensure our customers receive the ultimate in quality and economy of service – and that means giving them that decisive edge over the competition. Whether surface finishing or shot blasting technology – during elaborate practical tests we will always find the optimum solution. In more than 50 countries we support our customers with a close-knit of subsidiaries and international agencies, giving them a complete range of machines to cover the key sectors in surface treatment technology, grinding, finishing and shot blasting, all from one source. You tell us what you need; we find the most economical and technically rational solution.

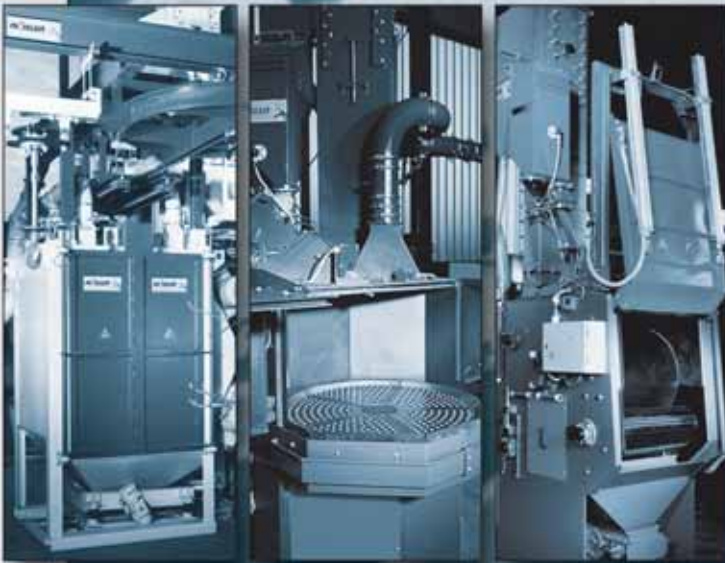



D RÖSLER Oberflächentechnik GmbH · Werk Memmelsdorf
Vorstadt 1 · D-96190 Untermerzsbach
Tel.: +49/9533/924-0 · Fax: +49/9533/924-300 · info@rosler.com

RÖSLER Oberflächentechnik GmbH · Werk Hausen
Hausen 1 · D-96231 Bad Staffelstein
Tel.: +49/9533/924-0 · Fax: +49/9533/924-300 · info@rosler.com

GB RÖSLER UK
Unity Grove, School Lane · Knowsley Business Park · GB-Prescot, Merseyside L34 9GT
Tel.: +44/151/4820444 · Fax: +44/151/4824400 · rosler@rosleruk.com

F RÖSLER France
Z.I. de la Fontaine d'Azon · B.P. 513 – St. Clément · F-89105 Sens Cedex
Tel.: +33/3/86647979 · Fax: +33/3/86655194 · rosler@rosler.fr

E RÖSLER International GmbH & Co. KG
Sucursal en España · Polg. Ind. Cova Solera C/Roma, 7 · E-08191 Rubí (Barcelona)
Tel.: +34/93/5885585 · Fax: +34/93/5883209 · rosler@rosler.es

I RÖSLER Italiana S.R.L.
Via E. Vittorini 10/12 · I-20049 Concorezzo (MI)
Tel.: +39/039/611521 · Fax: +39/039/6115232 · info@rosler.it

NL RÖSLER Benelux B.V.
Reggestraat 18 · NL-5347 JG Oss · Postbus 829 · NL-5340 AV Oss
Tel.: +31/412/646600 · Fax: +31/412/646046 · info@rosler-benelux.nl

B RÖSLER Benelux B.V.
Avenue de Ramelot 6 · Zoning Industriel · B-1480 Tubize (Saintes)
Tel.: +32/2/3610200 · Fax: +32/2/3612831 · info@rosler-benelux.be

A ROSLER Oberflächentechnik GmbH
Hetmanekgasse 15 · A-1230 Wien
Tel.: +43/1/6985180-0 · Fax: +43/1/6985182 · office@rosler.at

CH ROSLER Schweiz AG
Staffelbachstraße 189 · Postfach 81 · CH-5054 Kirchleerau
Tel.: +41/62/7385500 · Fax: +41/62/7385580 · info@rosler.ch

USA RÖSLER Metal Finishing USA L.L.C.
1551 Denso Road · USA-Battle Creek · MI 49015
Tel.: +1/269/4413000 · Fax: +1/269/4413001 · info@rosler.us

BR ROSLER do Brasil LTDA
Estrada dos Galdinos 35 · Jd. Barbacena · 06700-000 · Cotia · São Paulo - Brasil
Tel.: +55/11/46123844 · Fax: +55/11/46123845 · rosler@rosler.com.br

ZA RÖSLER S.A. Surface Technologies
P.O. Box 7949 · 66 Regency Drive · Route 21 Corporate Park · Irene Ext. 31 · 0046 Centurion
Tel.: +27/12/345 2215 · Fax: +27/12/345 3731 · johanv@roslersa.co.za

CN RÖSLER – BEIJING
Office 11N, Tower A, Beijing Fu Hua Mansion · No. 8, Chaoyangmen North Avenue
Dong Cheng District · Beijing 100027 P.R. China
Tel.: +86/10/6554 73 86 · +86/10/6554 73 89 · Fax: +86/10/6554 73 87 · info@rosler.com.cn

- and more than 60 representations worldwide

